

Notice d'Assemblage 13481133

**CALI
COSY.**

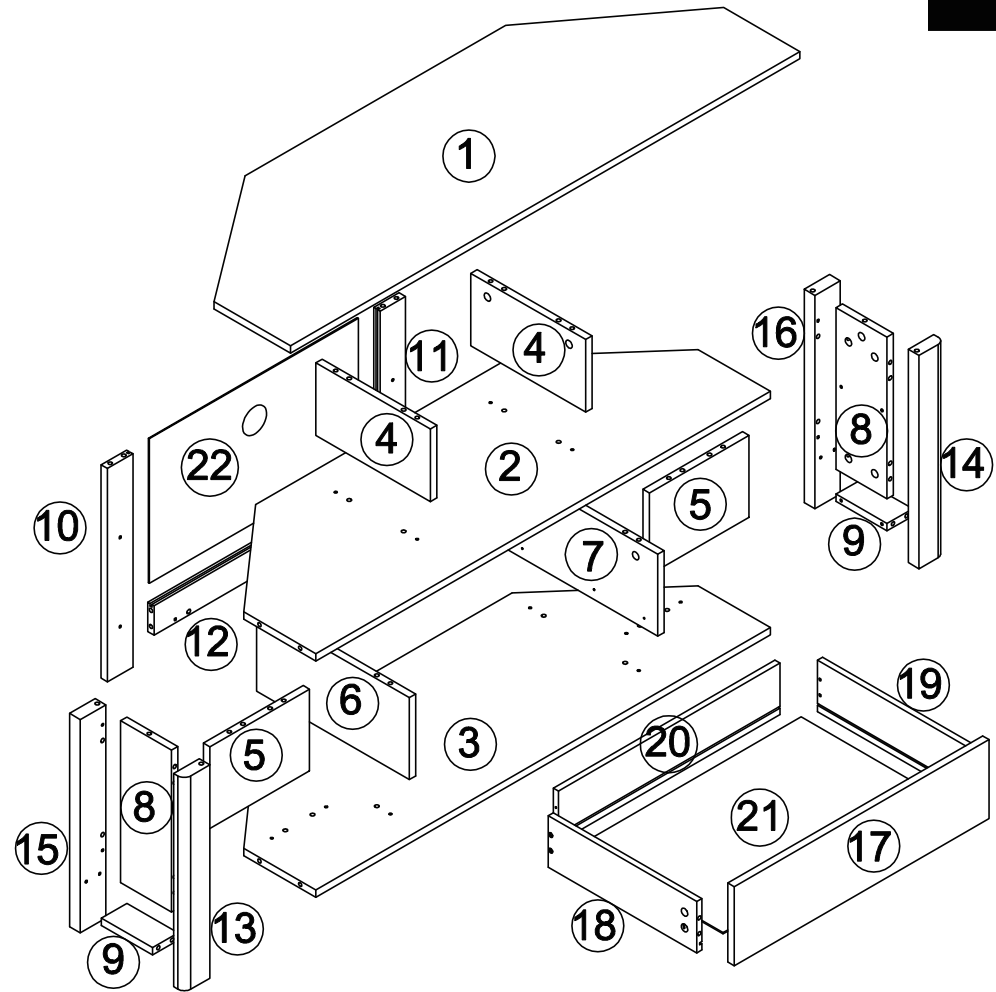

A

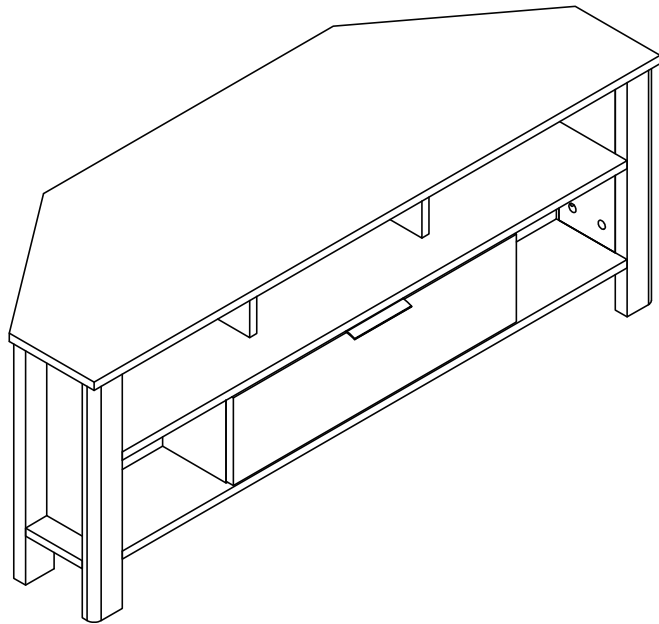
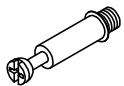

x48pcs

B



x48pcs

C



x42pcs

D



x20pcs

E



x14pcs

F

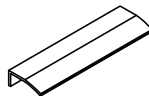

x1pc

CL

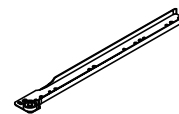

x1pc

CR

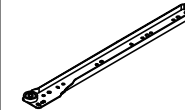

x1pc

DL

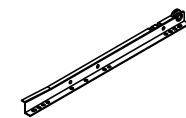

x1pc

DR

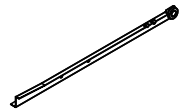

x1pc

Etape 1

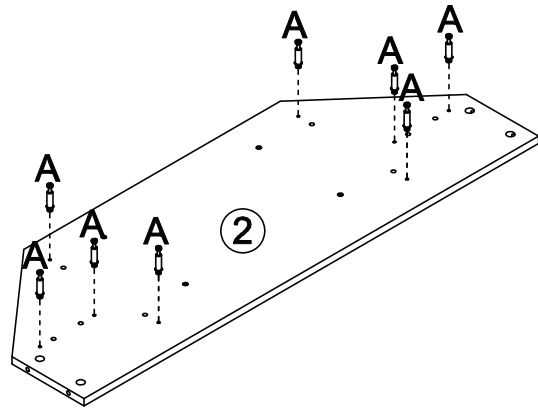

Etape 2

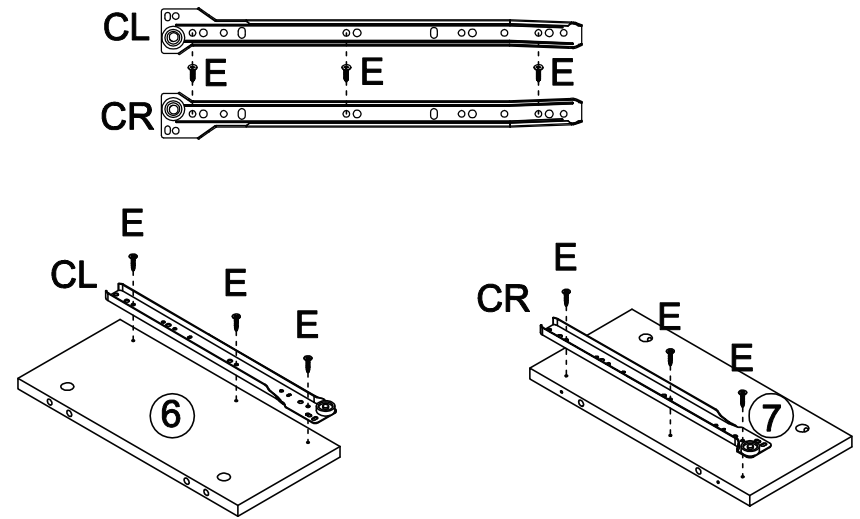

Etape 3

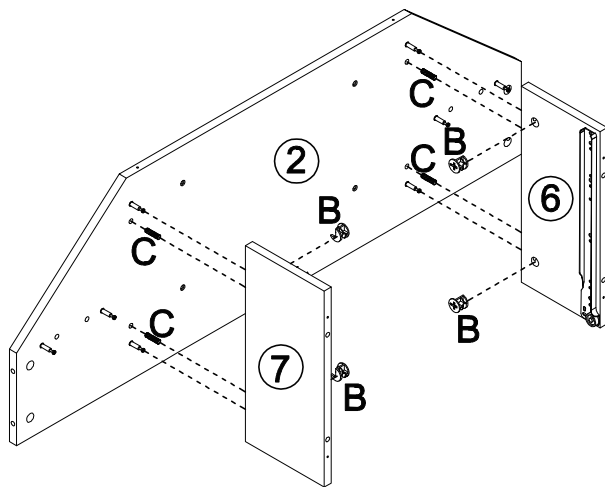

Etape 4

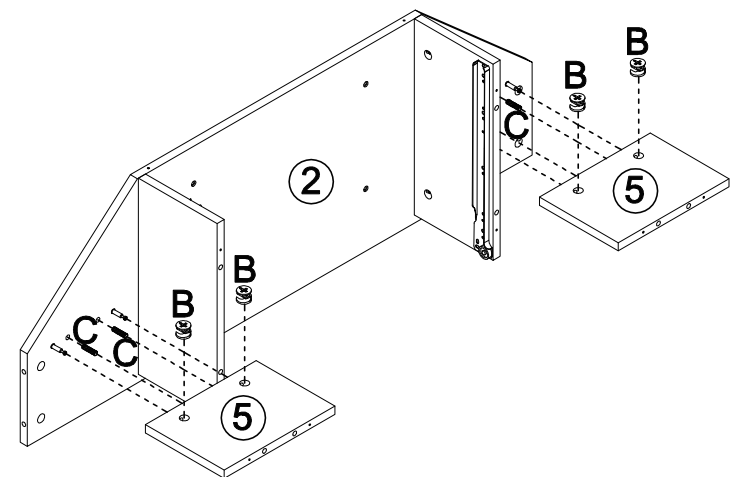

Etape 5

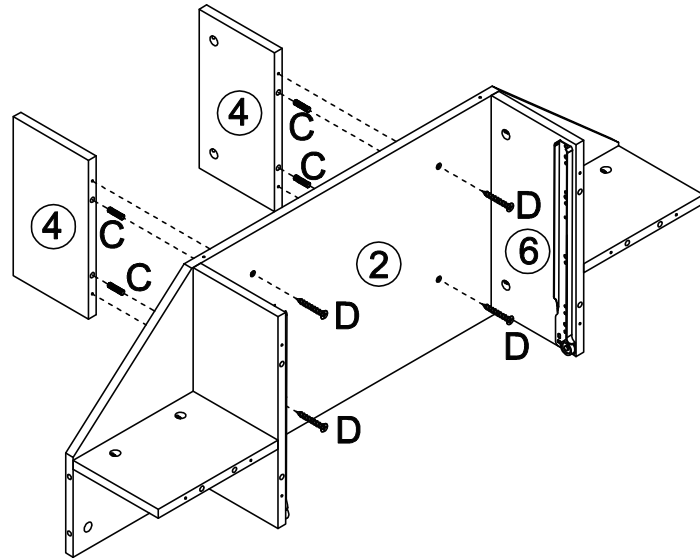

Etape 6

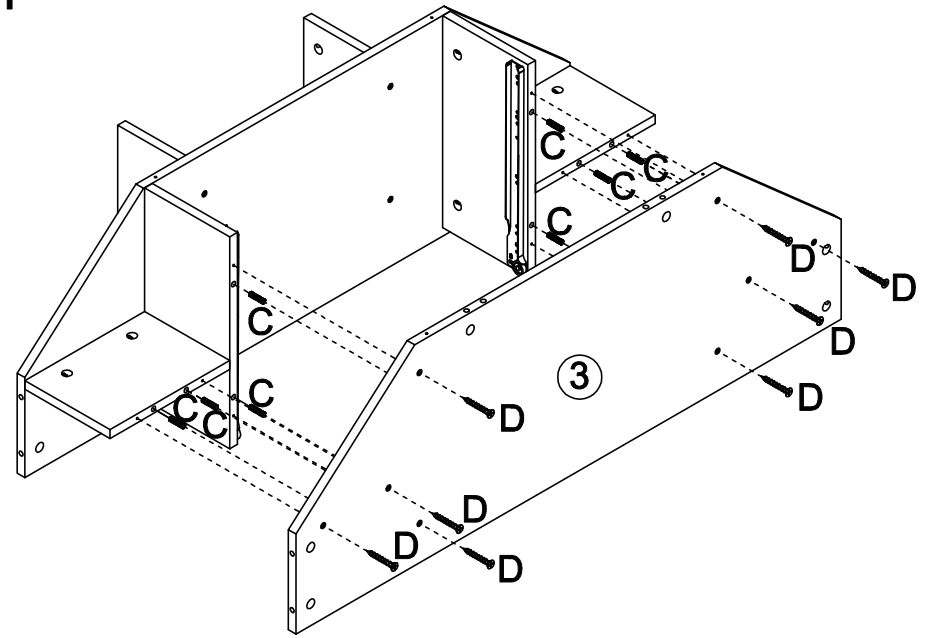

Etape 7

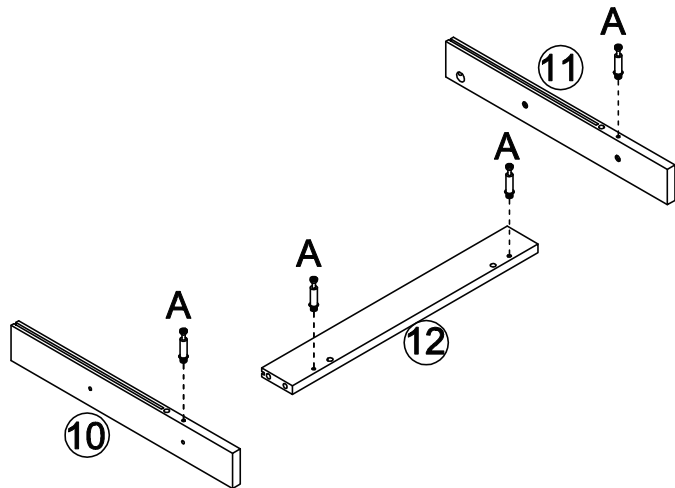

Etape 8

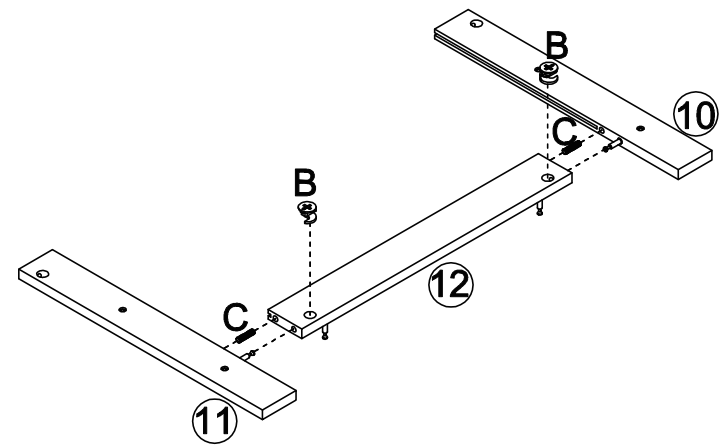

Etape 9

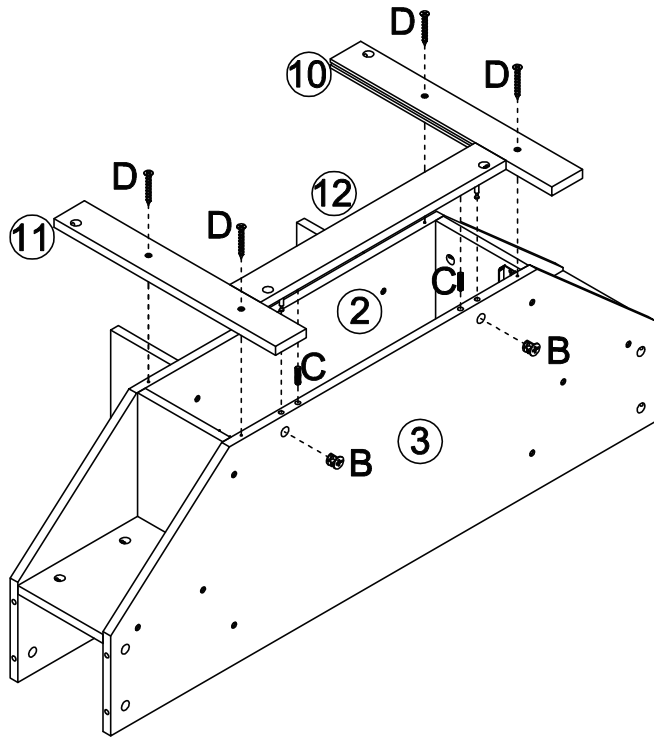

Etape 10

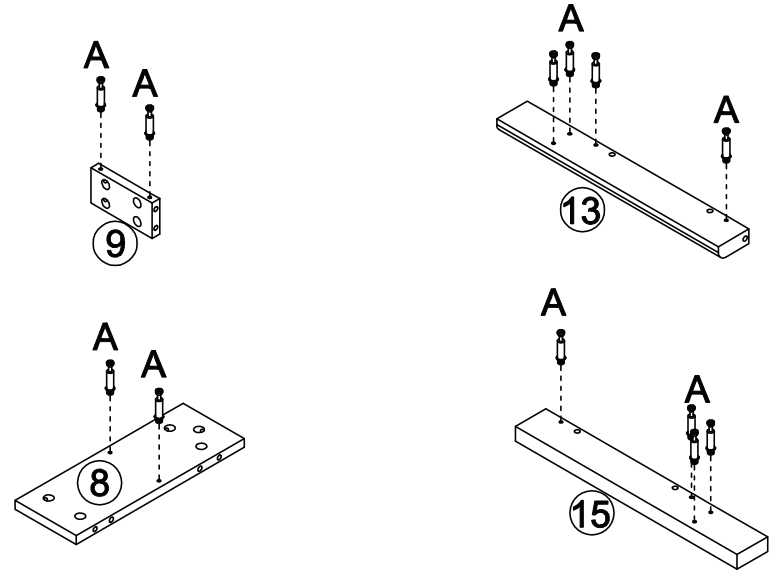

Etape 11

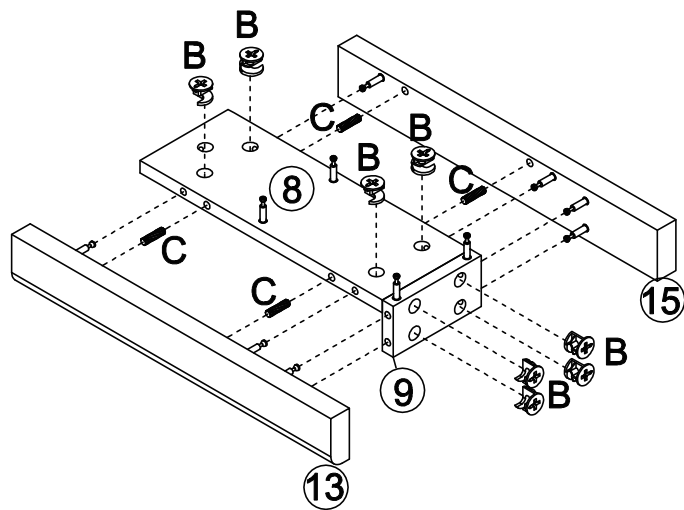

Etape 12

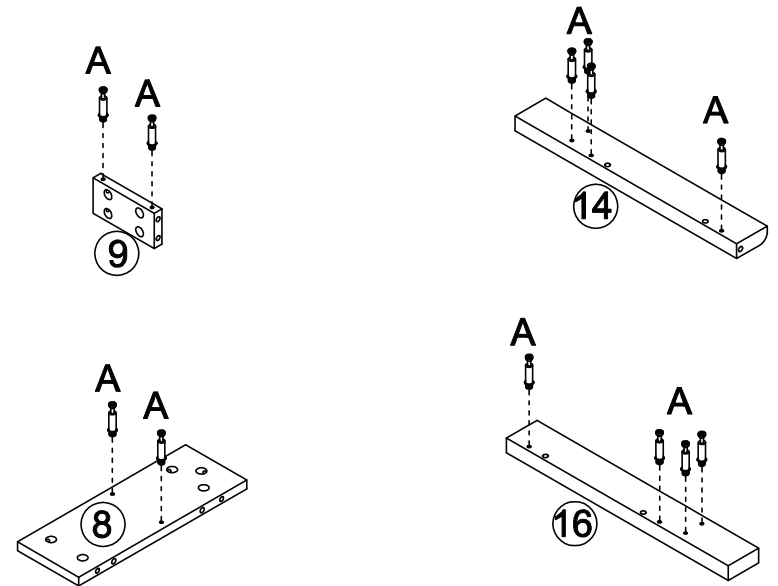

Etape 13

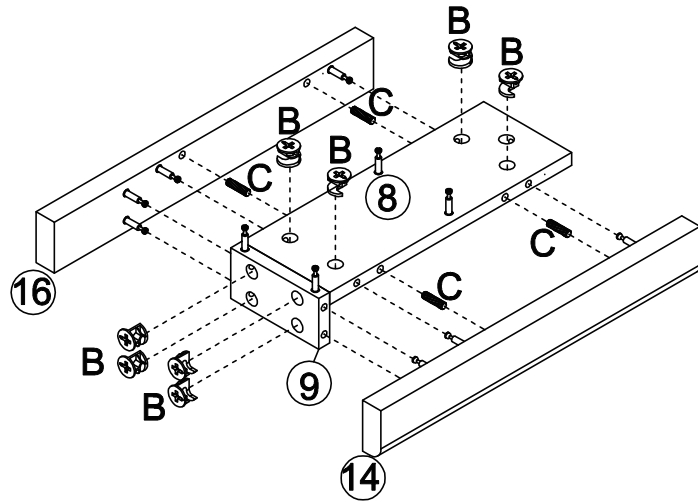

Etape 14

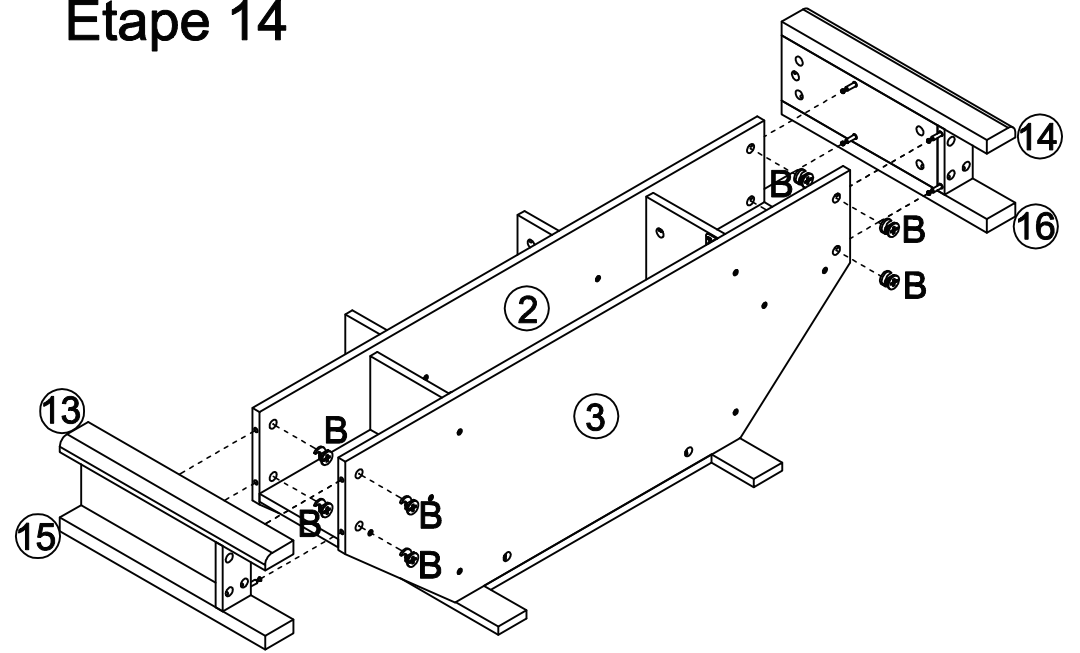

Etape 15

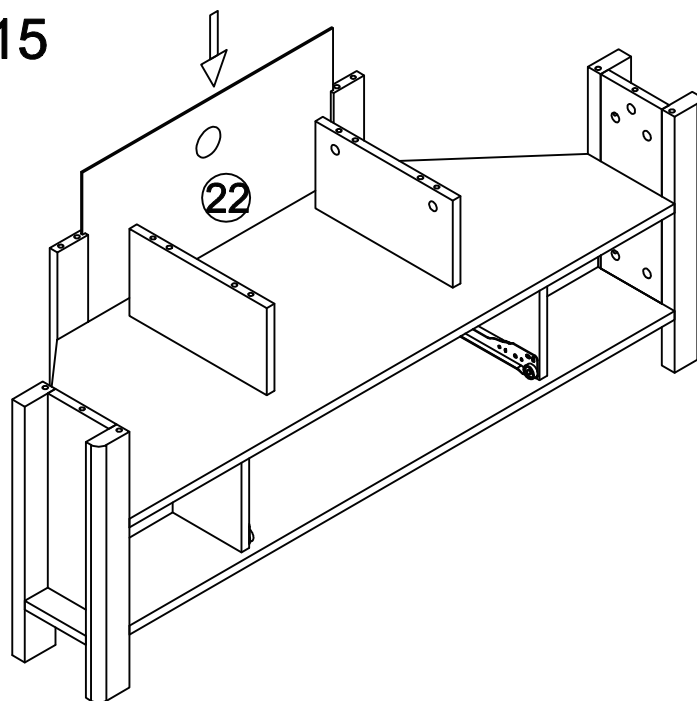

Etape 16

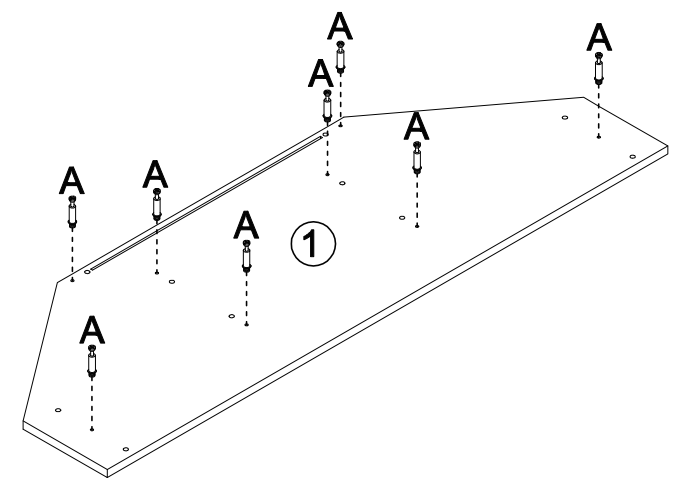

Etape 17

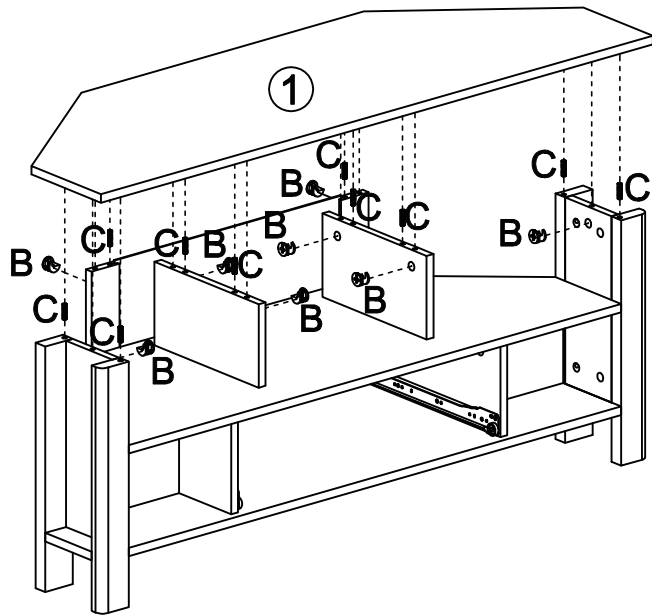

Etape 18

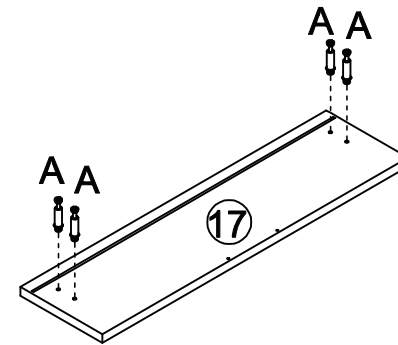

Etape 19

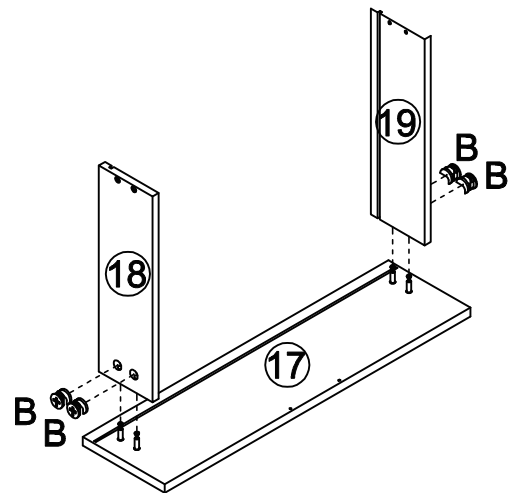

Etape 20

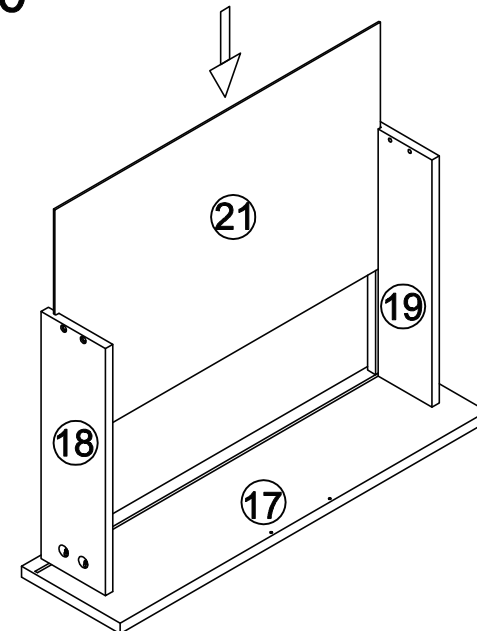

Etape 21

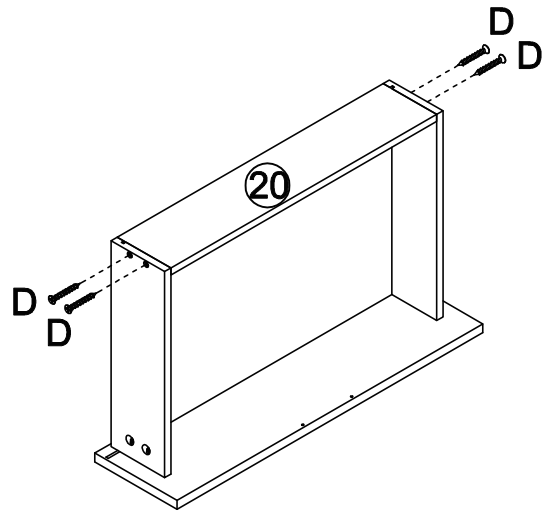

Etape 22

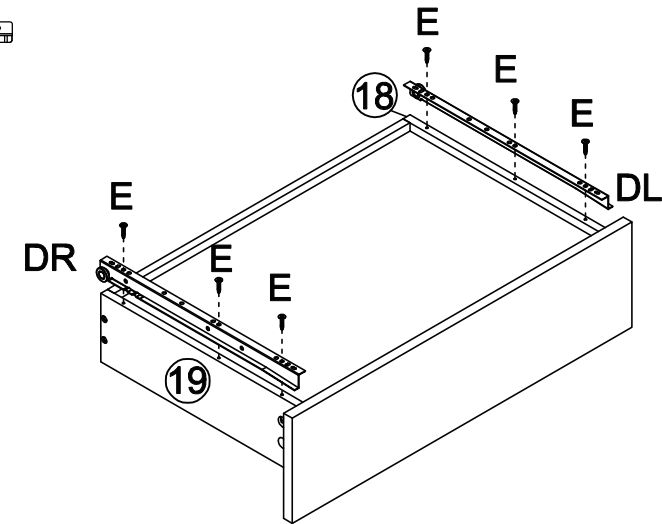
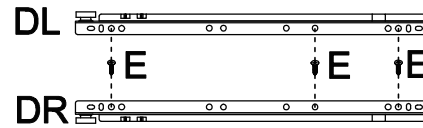

Etape 23

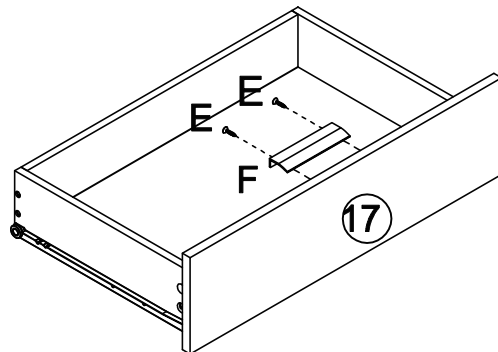

Etape 24

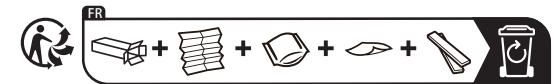
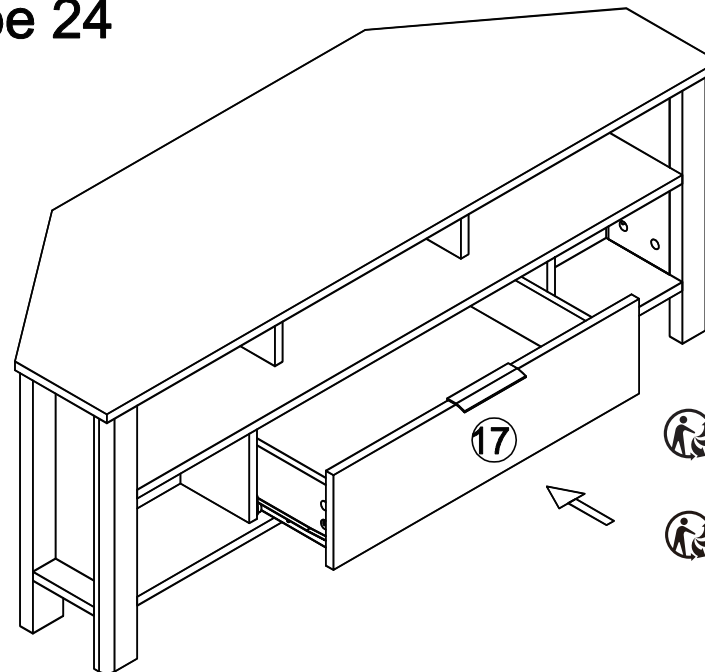

Importé par : SOSMART
7 chemin du Château d'Eau
59700 Marcq en Baroeul
France

CONSEILS D'ENTRETIEN / MAINTENANCE TIPS / CONSEJOS DE
MANTENIMIENTO / DICAS DE MANUTENCAO / CONSIGLI PER LA
MANUTENZIONE / WARTUNGSTIPPS / ONDERHOUDSTIPS / WSKAZÓWKI
DOTYCZĄCE KONSERWACJI / UNDERHÅLLSTIPS

- FR** Nettoyer avec un chiffon imbibé d'un détergent doux. Terminer en essuyant avec un chiffon sec. Proscrire tout abrasif et produits acides. Ne jamais employer de solvants.
- EN** Clean with a cloth dampened with a mild detergent. Finish by wiping with a dry cloth. Avoid all abrasives and acidic products. Never use solvents.
- ES** Limpiar con un paño humedecido con un detergente suave. Termine limpiando con un paño seco. Evite todos los productos abrasivos y ácidos. Nunca utilice disolventes.
- PT** Limpe com um pano humedecido com detergente neutro. Termine passando um pano seco. Evite todos os abrasivos e produtos ácidos. Nunca utilize solventes.
- IT** Consigli per la manutenzione. Pulire con un panno inumidito con un detergente delicato. Terminare strofinando con un panno asciutto. Evitare tutti i prodotti abrasivi e acidi. Non utilizzare mai solventi.
- DE** Mit einem milden Reinigungsmittel angefeuchteten Tuch reinigen. Zum Schluss mit einem trockenen Tuch abwischen. Vermeiden Sie alle Scheuermittel und säurehaltigen Produkte. Verwenden Sie niemals Lösungsmittel.
- NL** Reinigen met een doek die is bevochtigd met een mild schoonmaakmiddel. Werk af door af te vegen met een droge doek. Vermijd alle schuurmiddelen en zure producten. Gebruik nooit oplosmiddelen.
- PL** Czyścić szmatką zwilżoną łagodnym detergentem. Zakończ wycierając suchą szmatką. Unikaj wszelkich środków ściernych i produktów kwaśnych. Nigdy nie używaj rozpuszczalników.
- SE** Rengör med en trasa fuktad med ett mild rengöringsmedel. Avsluta med att torka av med en torr trasa. Undvik alla slipmedel och sura produkter. Använd aldrig lösningsmedel.